

VA9104-xGA-2S Series Electric Non-Spring Return Valve Actuators

Installation Instructions

Part No. 14-1336-15, Rev. C
Issued July 6, 2011
Supersedes December 28, 2007

Refer to the [QuickLIT Web site](#) for the most up-to-date version of this document.

Applications

The VA9104 Series Actuators are direct-mount, non-spring return electric valve actuators that operate on AC 24 V power. These synchronous, motor-driven actuators are used to provide accurate positioning on Johnson Controls® VG1000 Series DN15, DN20, and DN25 (1/2, 3/4, and 1 in.) ball valves in Heating, Ventilating, and Air Conditioning (HVAC) applications.

The VA9104 Series Electric Non-Spring Return Actuators provide a running torque of 35 lb-in (4 N·m). The nominal travel time is 60 seconds at 60 Hz (72 seconds at 50 Hz) for 90° of rotation.

IMPORTANT: Use this VA9104 Series Electric Non-Spring Return Valve Actuator only to control valves under normal operating conditions. Where failure or malfunction of the VA9104 Series electric actuator could lead to personal injury or property damage to the controlled equipment or other property, additional precautions must be designed into the control system. Incorporate and maintain other devices, such as supervisory or alarm systems or safety or limit controls, intended to warn of or protect against failure or malfunction of the VA9104 Series electric actuator.

Installation

Install the ball valve with the actuator at or above the centerline of the horizontal piping (see Figure 1).

IMPORTANT: Before specifying VA9104 Series Electric Non-Spring Return Valve Actuators for plenum applications, verify acceptance of exposed plastic materials in plenum areas with the local building authority. Building codes for plenum requirements vary by location. Some local building authorities accept compliance to UL 1995, Heating and Cooling Equipment, while others use different acceptance criteria.

IMPORTANT: Do not install or use this VA9104 Series Electric Non-Spring Return Valve Actuator in or near environments where corrosive substances or vapors could be present. Exposure of the electric actuator to corrosive environments may damage the internal components of the device, and will void the warranty.

Special Tool Needed

To install the actuator, use a digital voltmeter or a M9000-200 Commissioning Tool.

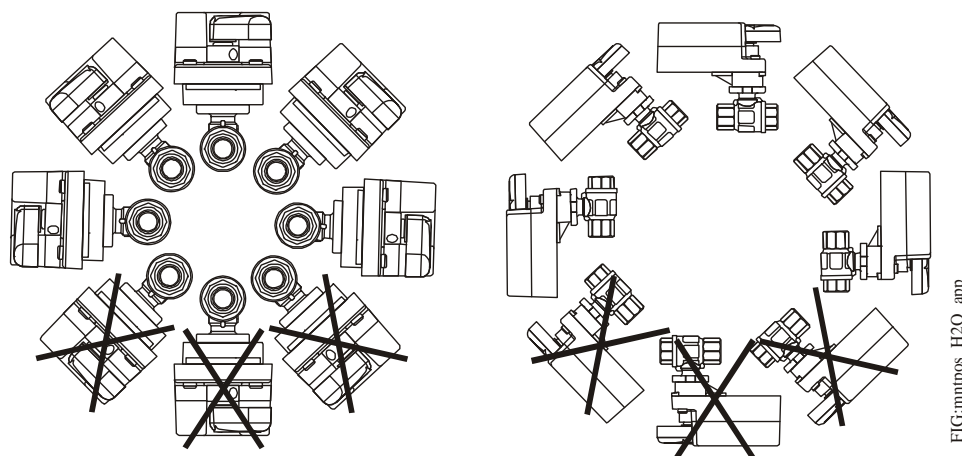

Figure 1: Mounting Positions for Chilled Water and Condensing Atmosphere Applications

Dimensions

See Figure 2 for dimensions of the Non-Spring Return VA9104 Actuated VG1241, VG1245, VG1841, and VG1845 Series Ball Valve with M9000-551 Linkage. See Table 1 for specific model linkage dimensions.

See Table 2 for specific model dimensions for the VA9104 Actuated VG1275 and VG1875 Series Sweat End and the VA9104 Actuated VG1295 and VG1895 Series Press End Connection Ball Valves.

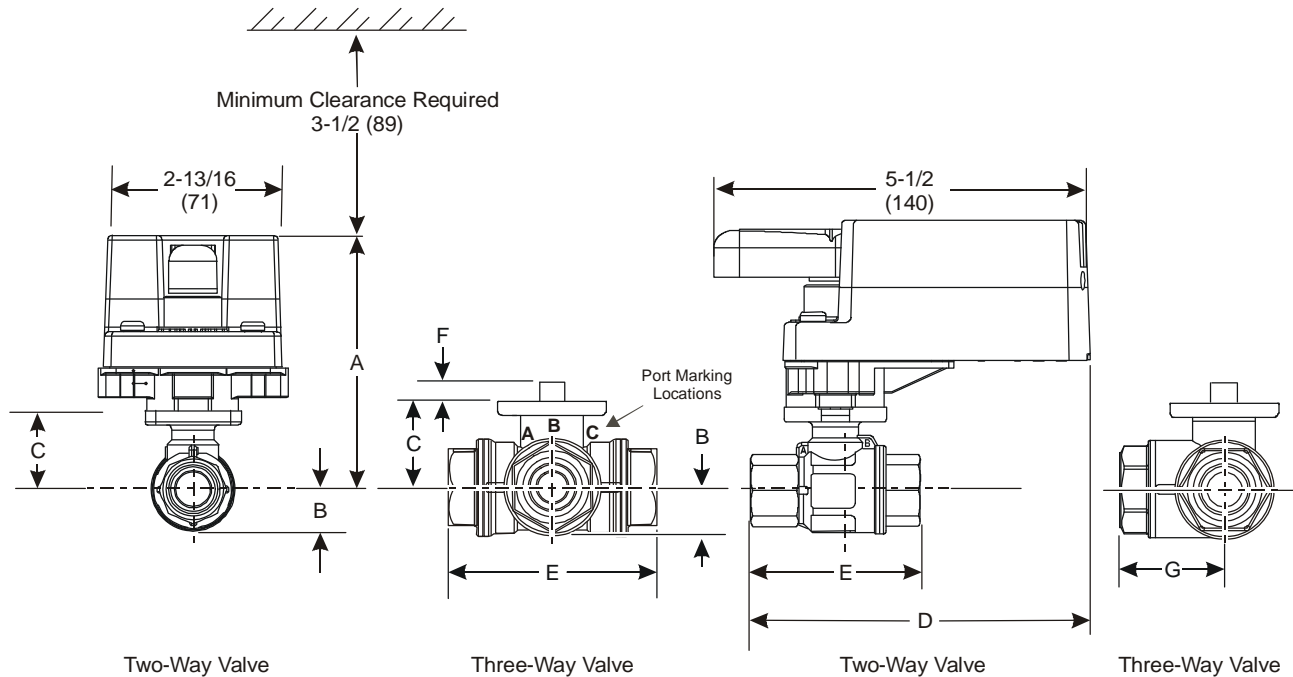

Figure 2: Non-Spring Return VA9104 Actuated VG1241, VG1245, VG1841, and VG1845 Series Ball Valve with Optional M9000-551 Linkage Dimensions, in. (mm.)

Table 1: VA9104 or M9104 Actuated VG1241, VG1245, VG1841, and VG1845 Series Ball Valve with Optional M9000-551 Linkage Dimensions, in. (mm)

Valve Size, in. (DN) ¹	A	B	C	D	E	F	G
1/2 (DN15)	3-7/8 (98)	21/32 (17)	1-7/32 (31)	5-7/64 (129)	2-33/64 (64)	11/32 (9)	1-1/4 (32)
3/4 (DN20)	3-7/8 (98)	21/32 (17)	1-7/32 (31)	5-7/32 (133)	2-51/64 (71)	11/32 (9)	1-13/32 (36)
1 (DN25)	3-11/16 (100)	3/4 (19)	1-19/64 (33)	5-9/16 (141)	3-13/32 (87)	11/32 (9)	1-11/16 (43)

1. Port A must always be connected to the coil (Figure 2).

Table 2: VA9104 Actuated VG1275 and VG1875 Series Ball Valve with Sweat End Connections and VA9104 Actuated VG1295 and VG1895 Series Ball Valves with Press End Connections Dimensions, in. (mm)

Valve Size, in. (DN) ¹	A	B	C	D	E	F	G
1/2 (DN15)	3-7/8 (98)	21/32 (17)	1-7/32 (31)	5-45/64 (145)	3-25/32 (96)	11/32 (9)	2-13/16 (55)
3/4 (DN20)	3-7/8 (98)	21/32 (17)	1-7/32 (31)	5-57/64 (150)	4-3/32 (104)	11/32 (9)	2-15/32 (62)
1 (DN25)	3-15/16 (100)	3/4 (19)	1-19/64 (33)	6-1/8 (156)	4 21/32 (118)	11/32 (9)	2-27/32 (72)

1. Port A must always be connected to the coil (Figure 2).

See Figure 3 and Table 3 for VA9104 Valve Actuator dimensions with optional M9000-561 Thermal Barrier installed.

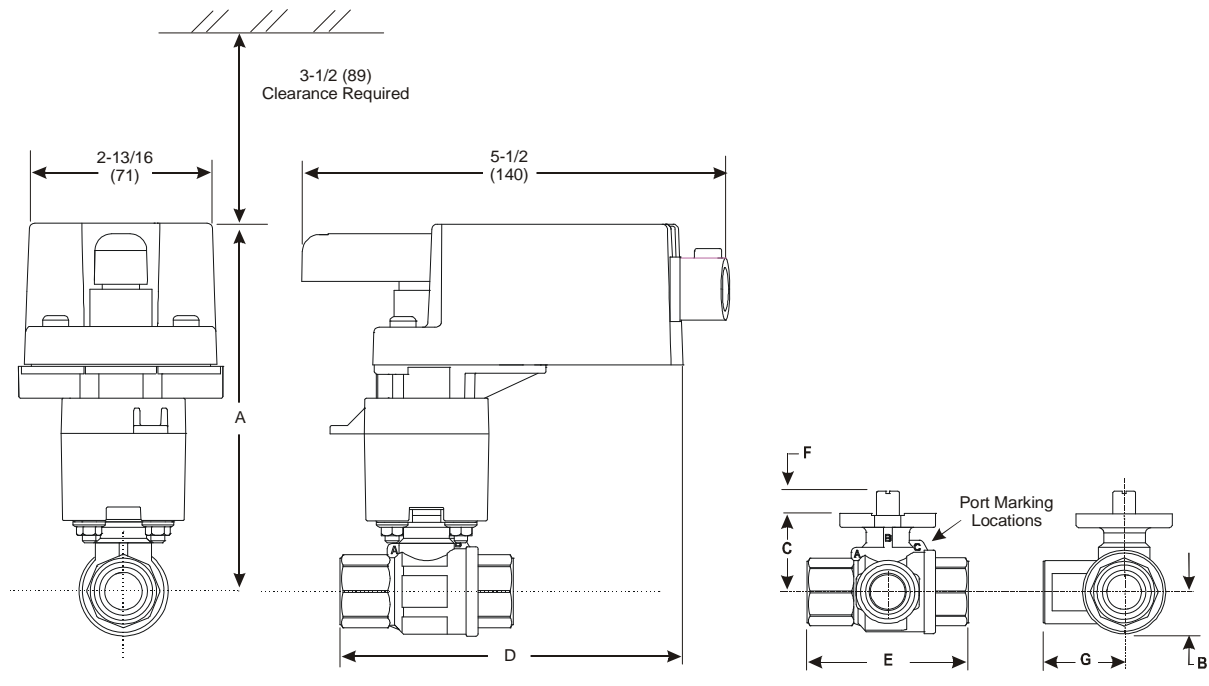

Figure 3: Field-Installed VA9104 Series Electric Actuator Dimensions with Optional M9000-561 Thermal Barrier Dimensions, in. (mm)

Table 3: VA9104 Actuated VG1241, VG1245, VG1841, and VG1845 Series NPT Ball Valves with Optional Thermal Barrier Installed Dimensions, in. (mm)

Valve Size, in. (DN) ¹	A	B	C	D	E	F	G
1/2 (DN15)	5-11/32 (135)	21/32 (17)	1-7/32 (31)	5-7/64 (129)	2-33/64 (64)	11/32 (9)	1-1/4 (32)
3/4 (DN20)	5-11/32 (135)	21/32 (17)	1-7/32 (31)	5-7/32 (133)	2-51/64 (71)	11/32 (9)	1-13/32 (36)
1 (DN25)	5-27/64 (137)	3/4 (19)	1-19/64 (33)	5-9/16 (141)	3-13/32 (87)	11/32 (9)	1-11/16 (43)

1. Port A must always be connected to the coil (Figure 3).

Accessories

Table 4: Accessories (Order Separately)

Code Number	Description
M9000-200	Commissioning Tool That Provides a Control Signal to Drive 24 V On/Off, Floating, Proportional, and/or Resistive Electric Actuators
M9000-561	Thermal Barrier Extends M(VA)9104, M(VA)9203, and M(VA)9208 Series Electric Spring Return Actuator Applications to Include Low Pressure Steam (Quantity 1)
M9000-341	Weathershield Kit for VG1000 Series Ball Valve Application of M(VA)9104, M(VA)9203, and M(VA)9208 Series Electric Spring Return Actuators (Quantity 1)

Mounting

Mounting the Actuator

To mount the actuator:

1. Turn valve stem to position below.

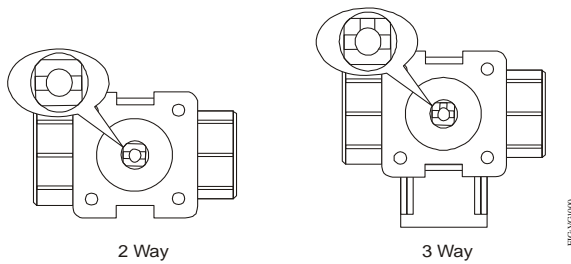

Figure 4: Positioning the Valve Stem

2. Mount optional M9000-561 Thermal Barrier to the valve if fluid temperature exceeds 212°F (100°C). See the [Mounting the Thermal Barrier](#) section for more information.
3. Place the handle the top of the drive shaft (Figure 5). The handle is keyed on and can only be mounted in one orientation..

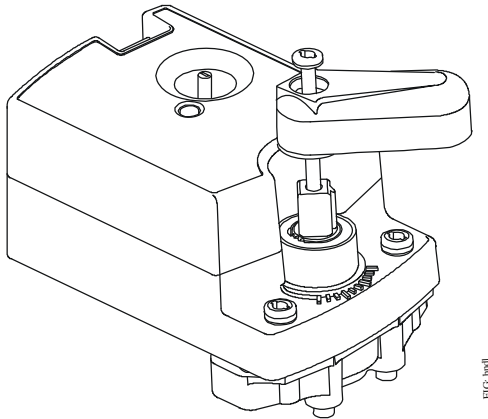

Figure 5: Installing the Handle

4. Check that the actuator coupler and handle are in the fully counterclockwise position as viewed from the top of the actuator. If not, press the actuator gear release and rotate the handle until the actuator coupler is fully counterclockwise.
5. Install the valve actuator over the ball valve mounting flange. Depending on the installation, position the assembly in any one of four 90° increments on the valve.

Note: For proper operation, the actuator must drive the valve counterclockwise to open Port A when viewed from above the valve.

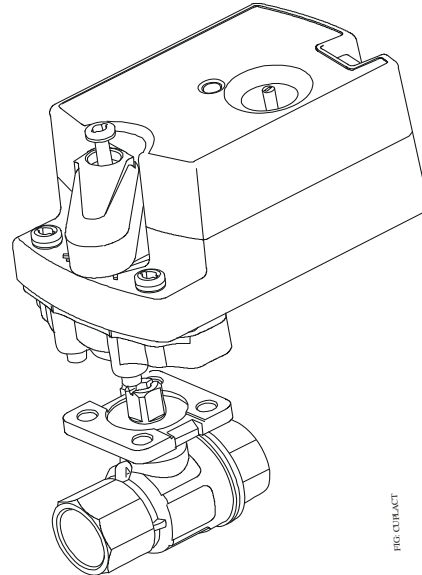

Figure 6: Coupling the Actuator to the Valve

6. To secure the actuator to the valve, use a 1/4 in. (6 mm) flat blade screwdriver. Recommended torque is 8 to 12 lb-in (0.9 to 1.4 N·m).

IMPORTANT: Do not overtighten the manual handle mounting screw. Overtightening may strip the threads resulting in damage to the valve stem threads.

Mounting the Thermal Barrier

Figure 7 shows the optional M9000-561 Thermal Barrier.

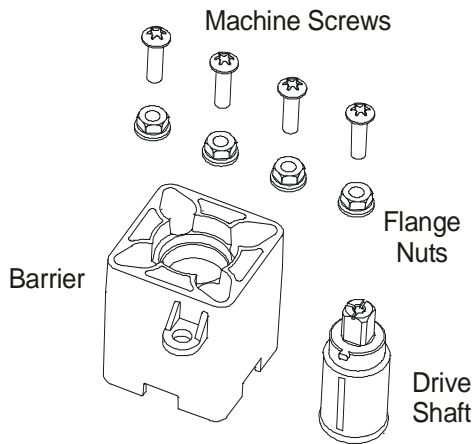

FIG: OPTNL

Figure 7: Optional M9000-561 Thermal Barrier

To mount the optional thermal barrier:

1. Install the thermal barrier drive shaft into the thermal barrier by aligning the tab on the drive shaft with the slot on the thermal barrier (Figure 8).

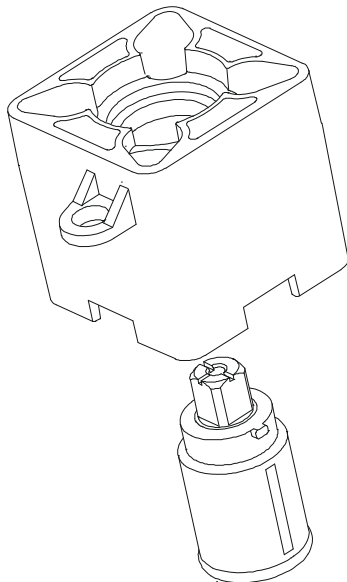

FIG: 8116

Figure 8: Installing the Drive Shaft into the Thermal Barrier

2. Rotate the drive shaft to align marks on the top of the thermal drive shaft with matching marks on the valve stem.
3. Mount the thermal barrier onto the valve using the four included M5x16 mm machine screws and four M5 flange nuts. Tighten the screws to a recommended torque of 21 to 25 lb-in. (2.4 to 2.8 N·m) (Figure 9).

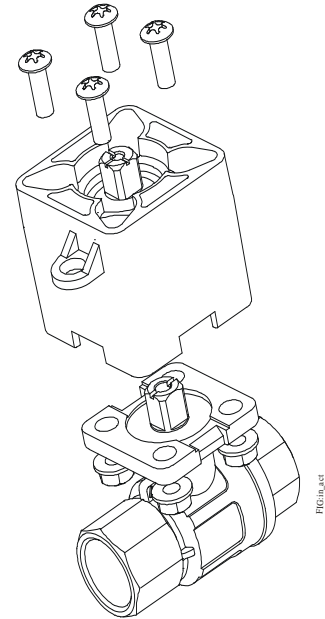

FIG: 9116

Figure 9: Installing the Barrier

4. Proceed to *Mounting the Actuator*. Follow the same steps as mounting directly to the valve when mounting the actuator to the thermal barrier.

Wiring

VA9104-AGA-2S and VA9104-IGA-2S

The VA9104-AGA and VA9104-IGA Series Electric Non-Spring Return valve actuators require an AC 24 V input signal and work with a variety of controllers. These electric actuators include an integrated 120 in. (3.05 m) long cable; see Figure 10 for proper wiring.

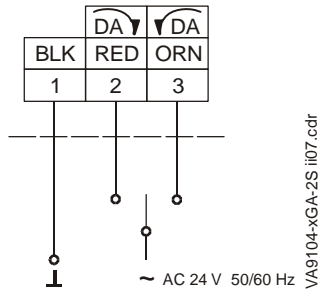

Figure 10: VA9104-AGA-2S and VA9104-IGA-2S Control Wiring Diagram

Note: For all VA9104-AGA Series actuators, use a controller and/or software that provides a timeout function at the end of rotation (stall) to avoid excessive wear or drive time on the actuator motor. The **-GGA** and **-IGA** models have an auto shutoff feature to prevent excessive wear or drive time on the motor.

VA9104-GGA-2S

The VA9104-GGA Series Electric Non-Spring Return valve actuators require AC 24 V power and a DC 0(2) to 10 V or 0(4) to 20 mA controller input signal. These electric actuators include an integrated 120 in. (3.05 m) long cable; see Figure 11 for proper wiring.

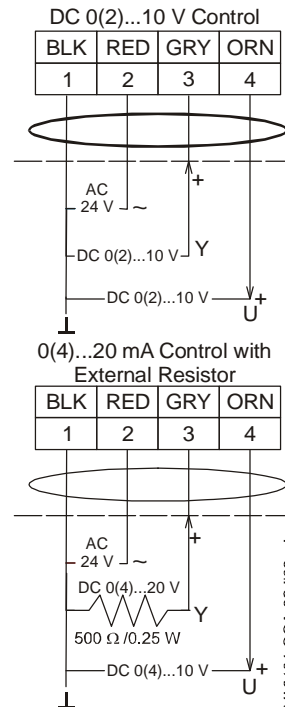

Figure 11: VA9104-GGA-2S Control Wiring Diagram

VA9104-GGA actuators are factory set for Direct Acting (DA) mode and for a DC 0 to 10 V input control signal. In DA mode, a minimum control signal drives the actuator to the full Counterclockwise (CCW) position, and a maximum control signal drives the actuator to the full Clockwise (CW) position.

For Reverse Acting (RA) operation, a minimum control signal drives the actuator to the full CW position and a maximum signal drives the actuator to the full CCW position. To change the factory settings, remove the actuator cover and adjust the switches on the circuit board as shown in Figure 12.

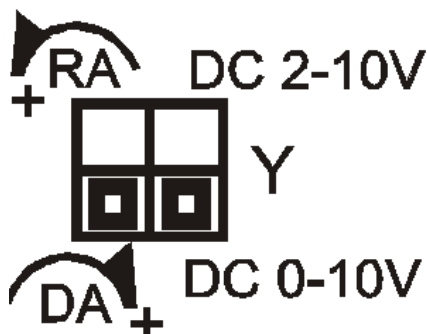

Figure 12: VA9104-GGA Factory Switch Setting



CAUTION: Risk of Electric Shock.
Disconnect the power supply before making electrical connections to avoid electric shock.



CAUTION: Risk of Property Damage.
Do not apply power to the system before checking all wiring connections. Short circuited or improperly connected wires may result in permanent damage to the equipment.

IMPORTANT: Make all wiring connections in accordance with local, national, and regional regulations. Do not exceed the electrical ratings of the VA9104 Series Electric Non-Spring Return Valve Actuator.

Setup and Adjustments

Commissioning

After wiring is complete, apply power to the Variable Air Volume (VAV) or Variable Air Volume and Temperature (VVT) controller and provide input signals to the actuator to drive it at least one complete cycle open and closed.

Troubleshooting

If the VA9104 Series Electric Non-Spring Return Valve Actuator is not responding or working properly:

- verify that the actuator assembly is properly secured to the valve.
- check that all electrical connections are complete and that power is applied.
- verify that the valve fully opens and closes, using the gear release button on the actuator and the manual override handle, shown in Figure 5.

Repairs

If the VA9104 Series Electric Non-Spring Return Actuator fails to operate within its specifications, replace the unit. For a replacement electric actuator, contact the nearest Johnson Controls representative.

Technical Specifications

VA9104-xGA-2S Electric Non-Spring Return Valve Actuators (Part 1 of 2)

Power Requirements		AC 24 V +25%/-20% at 50/60 Hz, 2.3 VA (AGA), 3.6 VA (GGA), and 3.0 VA (IGA) Supply, Class 2 or Safety Extra-Low Voltage (SELV)
Control Type	VA9104-AGA-2S	Floating or On/Off Control without Timeout
	VA9104-GGA-2S	Proportional Control
	VA9104-IGA-2S	Floating or On/Off Control with Timeout
Input Signal	VA9104-AGA-2S	AC 24 V +25%/-20% at 50/60 Hz, Class 2 or SELV without Timeout
	VA9104-GGA-2S	DC 0 (2) to 10 V or 0 (4) to 20 mA with Field-Furnished 500 ohm Resistor
	VA9104-IGA-2S	AC 24 V +25%/-20% at 50/60 Hz, Class 2 or SELV with Timeout
Feedback Signal	VA9104-GGA-2S	DC 0 (2) to 10 V for 90° Corresponds to Input Signal Span Selected
Motor Input Impedance	VA9104-AGA-2S	200 ohms Nominal
Control Input Impedance	VA9104-GGA-2S	Voltage Input: 200,000 ohm Current Input: 500 ohm With Field-Furnished 500 ohm Resistor
Running Torque		35 lb·in (4 N·m)
Travel Time		60 Seconds at 60 Hz (72 Seconds at 50 Hz) for 90° of Rotation
Rotation Range		93° ±3°, CW or CCW

VA9104-xGA-2S Electric Non-Spring Return Valve Actuators (Part 2 of 2)

Cycles		100,000 Full Stroke Cycles; 2,500,000 Repositions at Rated Running Torque
Audible Noise Rating		35 dBA Nominal at 39-13/32 in. (1 m)
Electrical Connections	VA9104-xGA-2S	120 in. (3.05 m) UL 444 Type CMP Plenum Rated cable with 19 AWG (0.75 mm ²) Conductors and 0.25 in. (6 mm) Ferrule Ends and Connector for 3/8 in. Flexible Metal Conduit
Enclosure	VA9104-xGA-2S	NEMA 2, IP42
Ambient Conditions	Operating	-4 to 140°F (-20 to 60°C); 90% RH Maximum, Noncondensing
	Storage	-20 to 150°F (-29 to 66°C); 90% RH Maximum, Noncondensing
Fluid Temperature Limits (Actuator and Valve Assembly)	VG12x1 and VG18x1 Series	23 to 203°F (-5 to 95°C)
	VG12x5 and VG18x5 Series	-22 to 212°F (-30 to 100°C)
	VG12x5 and VG18x5 Series with M9000-561 Thermal Barrier	-22 to 284°F (-30 to 140°C) Water; 15 psig (103 kPa) at 250°F (121°C) Saturated Steam
Compliance	United States	UL Listed, CCN XAPX, File E27734; to UL 60730-1A: 2003-08, Ed. 3.1, Automatic Electrical Controls for Household and Similar Use; and UL 60730-2-14: 2002-02, Ed. 1, Part 2 Particular Requirements for Electric Actuators (All Models) Actuator Housing is Plenum Rated per CSA C22.2 No. 236/UL 1995, Heating and Cooling Equipment
	Canada	UL Listed, CCN XAPX7, File E27734; to UL 60730-1:02-CAN/CSA: July 2002, 3rd Ed., Automatic Electrical Controls for Household and Similar Use; and CSA C22.2 No. 24-93 Temperature Indicating and Regulating Equipment (All Models) Actuator Housing is Plenum Rated per CSA C22.2 No. 236/UL 1995, Heating and Cooling Equipment
	Europe	CE Mark – Johnson Controls, Inc., declares that this product is in compliance with the essential requirements and other relevant provisions of the EMC Directive 2004/108/EC and the Low Voltage Directive 2006/95/EC.
	Australia and New Zealand	C-Tick Mark, Australia/NZ Emissions Compliant
Shipping Weight		1.25 lb (0.55 kg)

The performance specifications are nominal and conform to acceptable industry standards. For application at conditions beyond these specifications, consult the local Johnson Controls office. Johnson Controls, Inc. shall not be liable for damages resulting from misapplication or misuse of its products.



Building Efficiency

507 E. Michigan Street, Milwaukee, WI 53202

Metasys® and Johnson Controls® are registered trademarks of Johnson Controls, Inc. All other marks herein are the marks of their respective owners. © 2011 Johnson Controls, Inc.